

## INDEX

SHEET NO.	SUBJECT
1	Concrete Railing, FC and FT Index and General Notes
2	Concrete Railing, FC
3	Concrete Railing, FT
4	Concrete Railing Placement

### GENERAL NOTES:

1. A joint shall be provided between the bridge railing and railing transition at the end of the bridge slab as shown on Standard Drawing E 706-CBRT-01.
2. For twin structures and other structures which are placed side by side, the distance from the back face of the railing to the coping shall be reduced to 0 on the median side.
3. For twin structures and other structures which are placed side by side, the distance from the front face (toe) of the railing to the coping shall be reduced to 1 ft. 4 in. on the median side.
4. All reinforcing bars designated E shall be epoxy coated.



INDIANA DEPARTMENT OF TRANSPORTATION

CONCRETE RAILING, FC AND FT  
INDEX AND GENERAL NOTES

SEPTEMBER 2019

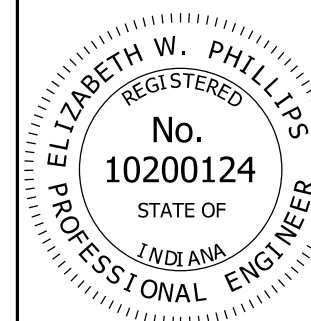
STANDARD DRAWING NO. E 706-BRSF-01



 DESIGN STANDARDS ENGINEER	5/2/2019 DATE
 CHIEF ENGINEER	6/5/2019 DATE



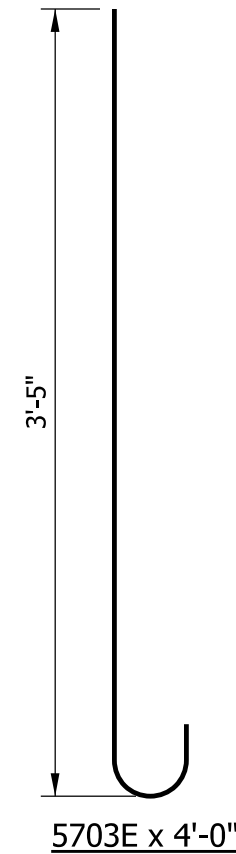
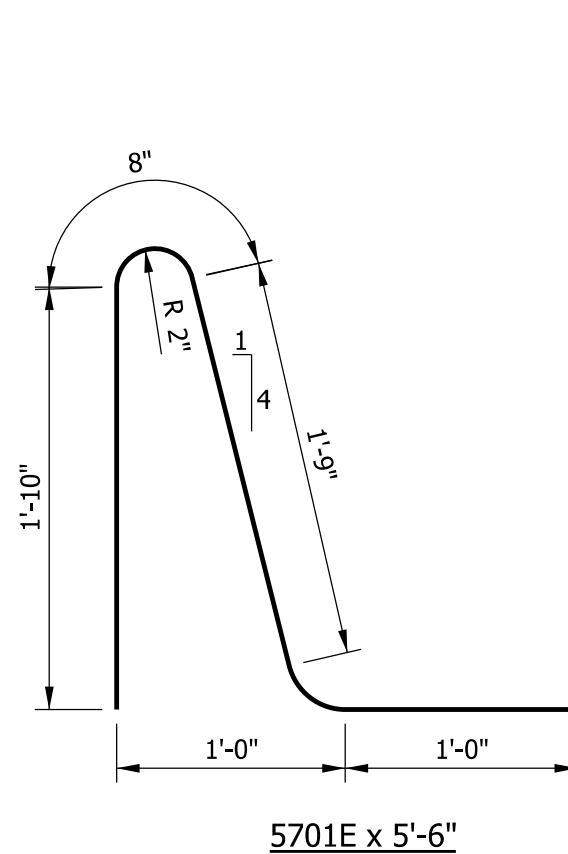
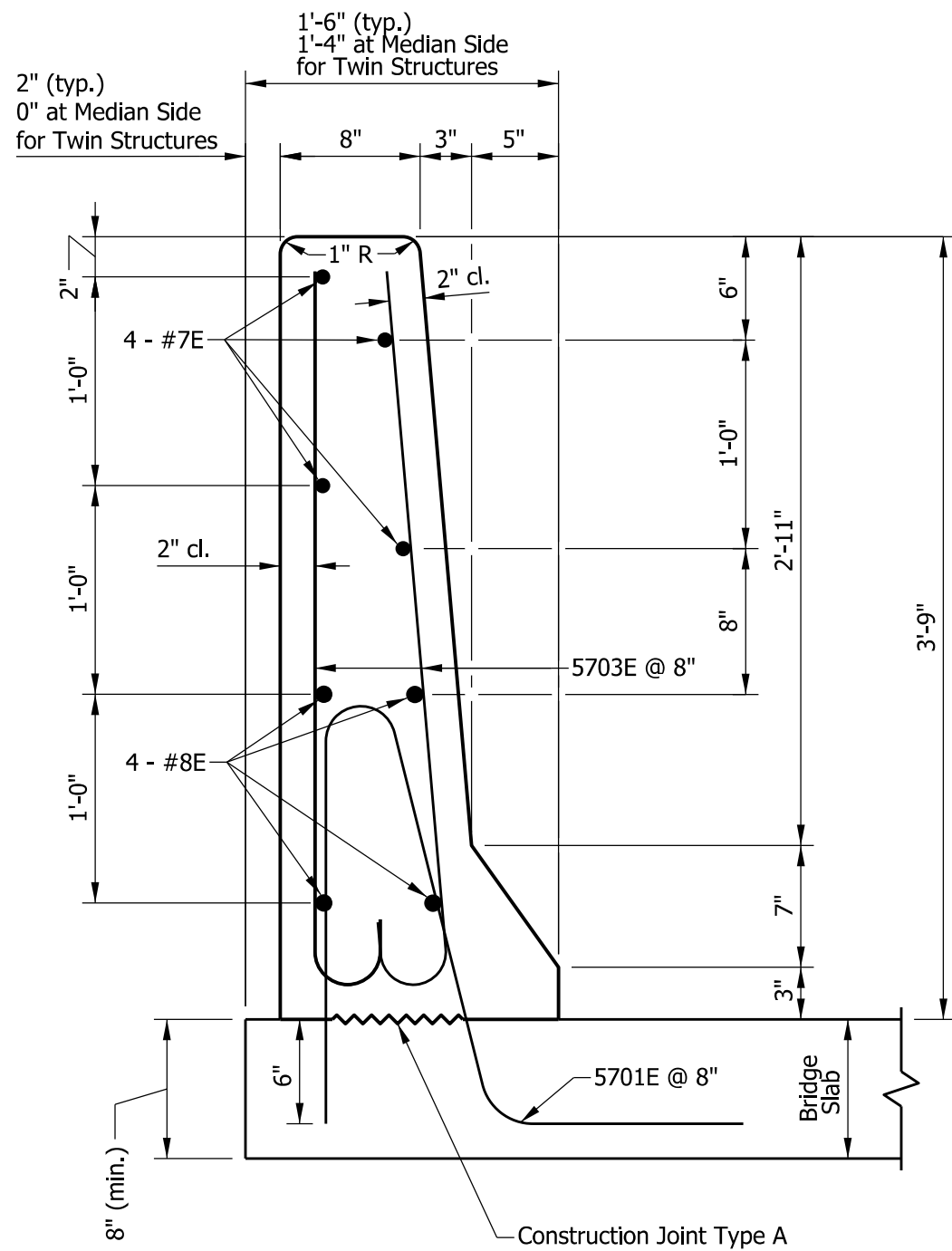

**NOTES:**

1. FT railing is acceptable as MASH Test Level 5.
2. See Standard Drawing E 703-BRST-01 for reinforcing-bar bending details and notes.
3. See Standard Drawing E 702-CJTA-01 for construction joint type A details.

QUANTITIES FOR ONE RUNNING FOOT OF RAILING	
Concrete, class C	3.29 CFT
Reinforcing bars*	40.0 LBS

\*Wt. of reinforcing bars doesn't include allowance for splices through longitudinal bars

INDIANA DEPARTMENT OF TRANSPORTATION	
CONCRETE RAILING, FT	
SEPTEMBER 2019	
STANDARD DRAWING NO.	E 706-BRSF-03
	 DESIGN STANDARDS ENGINEER 5/2/2019 DATE
	 CHIEF ENGINEER 6/5/2019 DATE

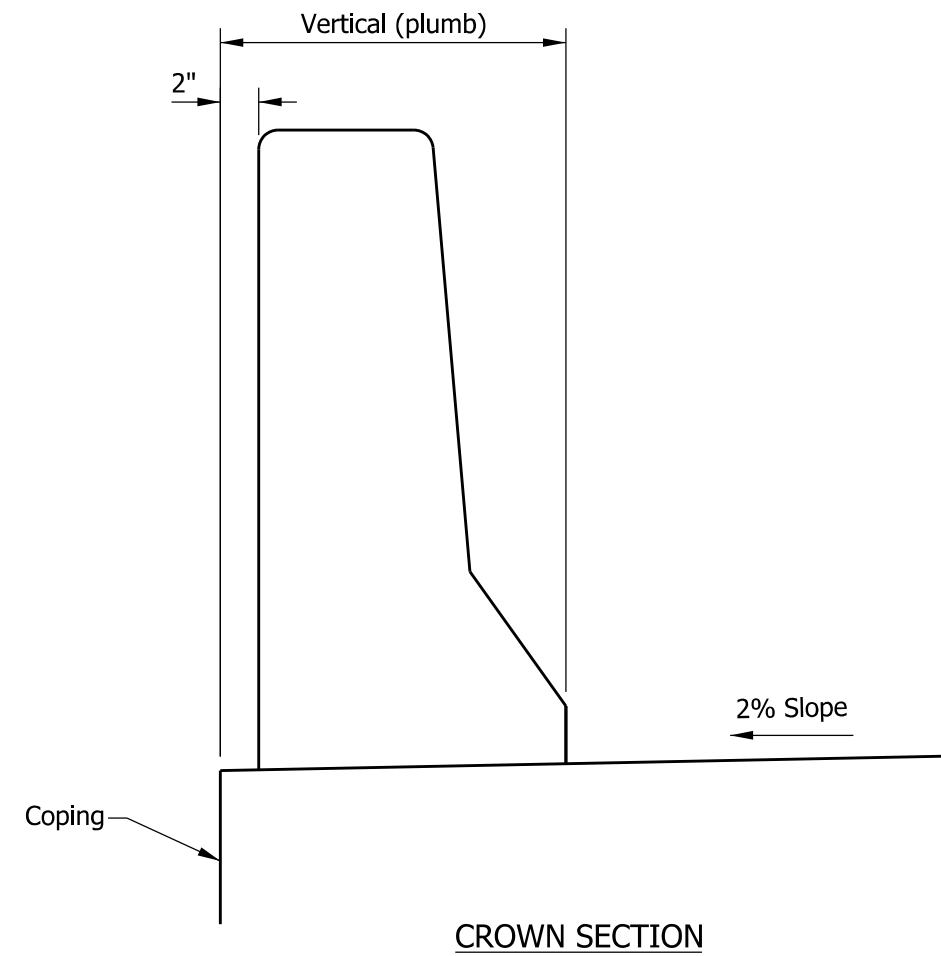
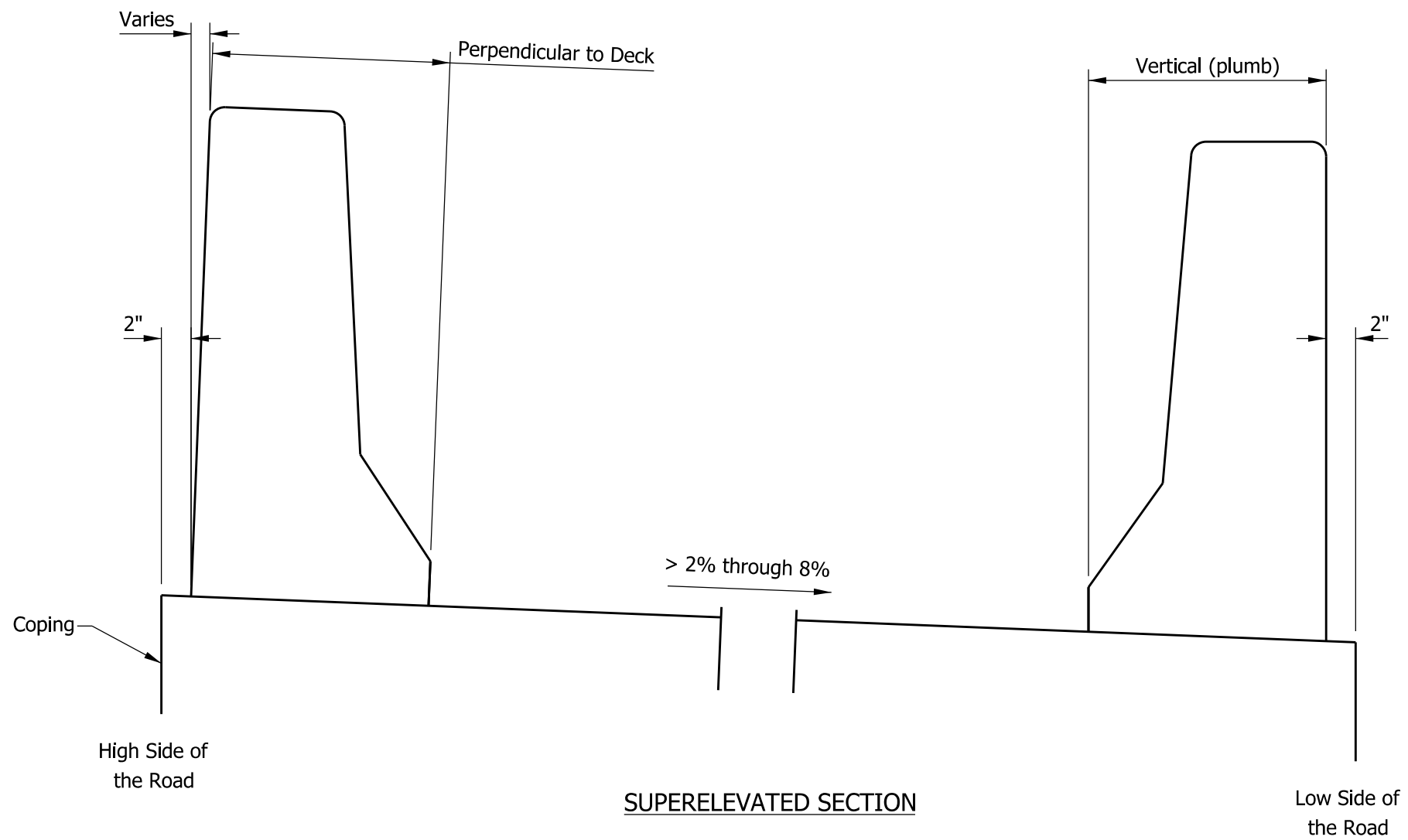

INDIANA DEPARTMENT OF TRANSPORTATION	
CONCRETE RAILING PLACEMENT	
SEPTEMBER 2019	
STANDARD DRAWING NO.	E 706-BRSF-04
	 DESIGN STANDARDS ENGINEER      5/2/2019 DATE
	 CHIEF ENGINEER      6/5/2019 DATE